

# IPC-I5615M-2R

15" LED High Performance Industrial  
Panel PC , Supports i7/i5/i3 Processor

## Features

1. 15" LED Panel support 1024 × 768pixel
2. Intel Core i7/i5/i3 Sandy bridge Processor
3. System memory 1 x DDR3 DIMM slot ,up to 8G 1066/1333MHz
4. Front 6mm aluminum bezel with IP65 compliant
5. Front hardness glass protect screen ( touch option )
6. 5COM (1x RS485), 1xDVI, 1x PS/2, 1xVGA, 6x2.0 USB, 2xLAN, 1x AUDIO、MIC
7. 1xPCI Express x16 Slot, 1 xMini PCIe slot
- 8.Back For Power LED and HDD LED Indication and 2x 3 Watts stereo speaker,
9. Wireless LAN with antenna (option),GPIO (option)
10. Panel ( Flush ) mount with clip
11. Wide range DC 8-30V input
12. Standard VESA 75/100mm support stand ,wall mount and swing arm

SUN-PC®  
www.sunpc-pc.com

8.4"/10.4"/12.1"/15"/17"/18.5"/22"

## 15" i3/i5/i7 LED PANEL PC



## I/O Appearance

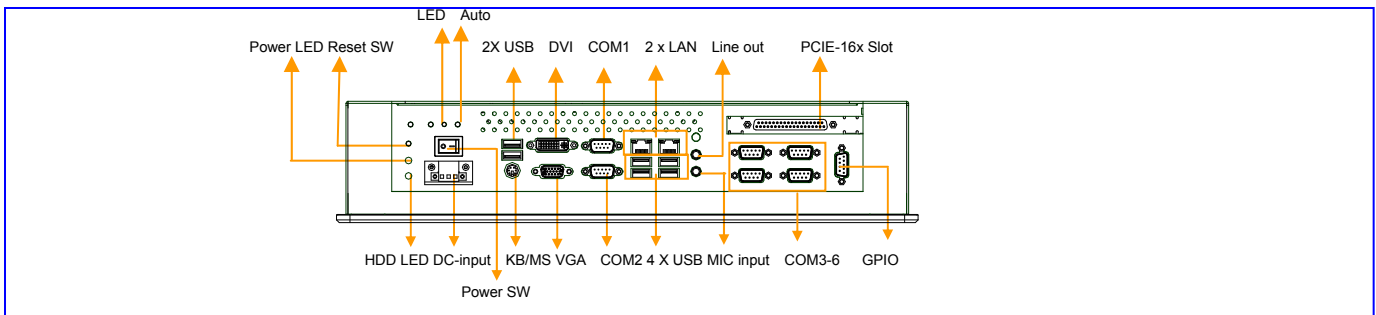

## Various applications

1. Advanced Control or data entry operator interfaces
2. Information management and retrievals
3. Entertainment management systems
4. Point of sale (POS) terminals
5. Banking /office automation

## Specifications

<b>System</b>	CPU	Intel Core i7/i5/i3 Sandy bridge Processor with 1066/1333 MHz FSB
	Chipset	Intel H61
	Memory	1x DIMM DDR3 800/1066/1333 SDRAM up to 8 GB
	HDD	Space for 1x 2.5" 320G SATA HDD
	Ethernet	Two LAN onboard: 2x Realtek® RL8111x (Gigabit) 10/100/1000 Ethernet
	Audio	Realtek® ALC662, 5.1 channel surround audio
	Mounting	Panel / VESA 75 X 75mm and 100 x 100mm
	Construction	Aluminum front bezel and Aluminum chassis
	Dimension WxHxD ( mm )	406 x 312 x 90mm
	NET Weight ( kgs )	8.5 KG

# IPC-I5615M-2R

15" LED High Performance Industrial  
Panel PC , Supports i7/i5/i3 Processor

<b>OS support</b>	Support DOS, Windows, Netware, Unix, Linux,	
<b>I/O Ports</b>	Serial ports	4 x RS-232, 1 x RS422/485
	DVI ports	1 x DVI-D port
	Keyboard and Mouse ports	PS/2
	VGA	DB-15 Connector
	Sound	Mic-in / Line-out
	Ethernet	2 x 10/100/1000MLAN port ( RJ-45 )
	USB port	6 x USB2.0
	DC input Connector	3Pin DC power input terminal block
<b>Environmental Specifications</b>	Operating Temperature	0 °C to 50°C
	Storage temperature	-20 °C to 60 °C
	Relative Humidity	10% to 90% non-condensing
	Shock (operating)	1G /peak ( 11m sec)
	Vibration	17 to 500HZ 1G PTP
	Front panel protection	IP65/NEMA 4 compliant
<b>LCD Display</b>	Display Type	15" LED TFT LCD Panel
	Screenresolution (Pixels)	1024 * 768
	Brightness	350cd/m2
	Viewing angle	160°(H) , 140°(V)
<b>Touch screen</b>	Internal USB interface controller	
	Resolution: continuous	
	Light transmission: 80% or more	
	Surface hardness : 3H	
	Operating force : ≤100g	
	Life expectancy : 35 Million	
	Support DOS, Windows, Netware, Unix, Linux,	
<b>Power Supply</b>	Output Rating 92W	
	Input Voltage : 8~30v, with External AC adapter*	

## Ordering Information

IPC-I5615M-2R-i3	15" LED XGA High Performance industrial panel pc with I3 3.4G (3240)Processor, with 2G RAM, 2.5" 320G HDD, With Resistive Touch screen, with 12V/120W external AC adapter
IPC-I5615M-2R-i5	15" LED XGA High Performance industrial panel pc with I5 3.6G (3470)Processor, with 2G RAM, 2.5" 320G HDD, With Resistive Touch screen, with 12V/120W external AC adapter
IPC-I5615M-2R-i7	15" LED XGA High Performance industrial panel pc with I7 3.9G (3770)Processor, with 2G RAM, 2.5" 320G HDD, With Resistive Touch screen, with 12V/120W external AC adapter
MP-MS150NW	Mini-PCIE wireless Lan card with antenna

## Dimension Diagram

