

FIPC-N28185W

18.5" Wide LED Fanless Industrial Compact Size Panel PC with intel® ATOM (Dual-core 1.86G) Processor

Features

1. 18.5" Wide LED WXGA TFT LCD Panel support 1366 × 768pixel
2. Intel Atom N2800 (Dual - core 1.86GHz processor) CPU with 667 MHz FSB
3. Front 6mm aluminum bezel with IP65 compliant and
4. Front hardness glass protect screen (touch option)
5. 5COM (1XRS422/485, 4 XRS232), 1 x HDMI, 1xVGA, 4xUSB, 2xLAN, 1x AUDIO
6. 2 x Mini PCIe slot
7. Back I/O For Power LED and HDD LED Indication
8. Wireless LAN with antenna (option)
9. Panel (Flush) mount with clip
10. DC 12V input, Wide range DC 8 - 30V input (option)
11. Standard VESA 75/100mm support stand ,wall mount and swing arm

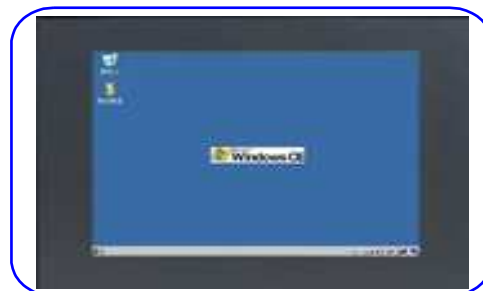

I/O Appearance

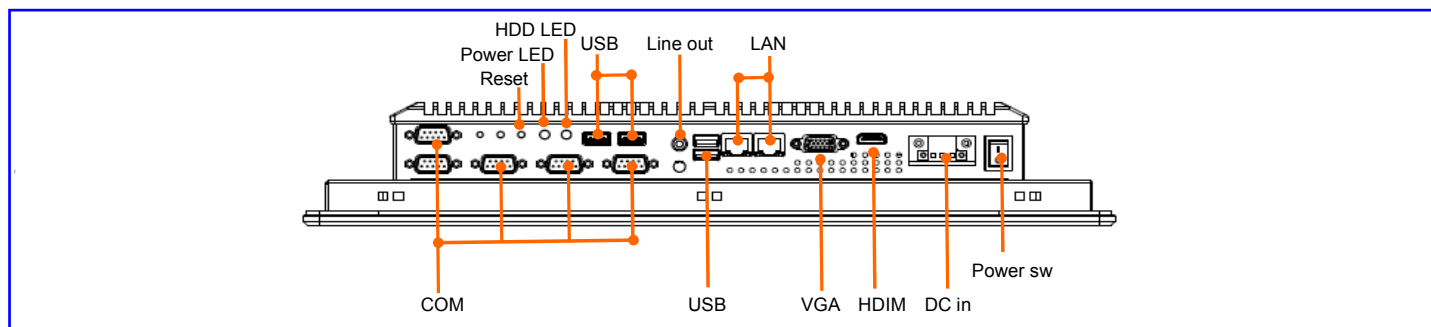

Various applications

1. Control or data entry operator interfaces
2. Information management and retrievals
3. Entertainment management systems
4. Banking /office automation

Specifications

Systems	CPU	Intel Atom D (Dual-core 1.86GHz processor) CPU with 667 MHz FSB
	Chipset	Intel Atom N2800 + NM10
	Memory	1x SODIMM DDR3 800/1066/1333 SDRAM up to 4 GB
	HDD	Space for 1x 2.5" 320G SATA HDD
	Ethernet	Two LAN onboard: 2x Realtek ® RL8111x (Gigabit) 10/100/1000Ethernet
	Graphic	Intel GMA3650 chipset
	Audio	Realtek ® ALC662, 5.1 channel surround audio
	Mounting	Panel / VESA 75 X 75mm and 100 x 100mm
	Construction	Aluminum front bezel and Aluminum chassis
	DimensionWxHxD (mm)	480 x 300 x 72mm
	Weight (kgs)	NW:8.0KG GW:9.5KG

FIPC-N28185W

18.5" Wide LED Fanless Industrial Compact Size Panel PC with intel® ATOM (Dual-core 1.86G) Processor

OS support	Support DOS, Windows, Netware, Unix, Linux,	
I/O Ports	Serial ports	4 x RS-232, 1x RS422/485
	HDMI ports	1 x HDMI
	VGA	DB-15 Connector
	Sound	Mic-in / Line-out
	Ethernet	2 x 10/100/1000MLAN port (RJ-45)
	USB port	4 x USB2.0
	DC input Connector	3Pin DC power input terminal block
Environmental Specifications	Operating Temperature	0 ° C to 50 ° C
	Storage temperature	-20 ° C to 60 ° C
	Relative Humidity	10% to 90% non-condensing
	Shock (operating)	1G /peak (11m sec)
	Vibration	17 to 500HZ 1G PTP
	Front panel protection	IP65/NEMA 4 compliant
LCD Display	Display Type	18.5" LED WXGA TFT LCD
	Screenresolution (Pixels)	1366*768
	Brightness	250cd/m2
	Viewing angle	160° (H) , 160° (V)
Touch screen	Internal USB interface controller	
	Resolution: continuous	
	Light transmission: 80% or more	
	Surface hardness : 3H	
	Operating force : ≤100g	
	Life expectancy : 35 Million	
Power Supply	Support DOS, Windows, Netware, Unix, Linux,	
	Output Rating 25W	
	Input Voltage : DC12V, with External AC adapter 12V/5A, 60W	

Ordering Information

FIPC-N28185W	18.5" wide LED SXGA Fanless Industrial Compact Size Panel PC support Intel® Atom N2800 Dual - core 1.86GHz Processor,with 2G RAM, 2.5" 320G HDD, with Resistive Touch Screen, DC12V AC Adapter
MP-MS150NW	Mini-PCIE wireless Lan card with antenna

Dimension Diagram

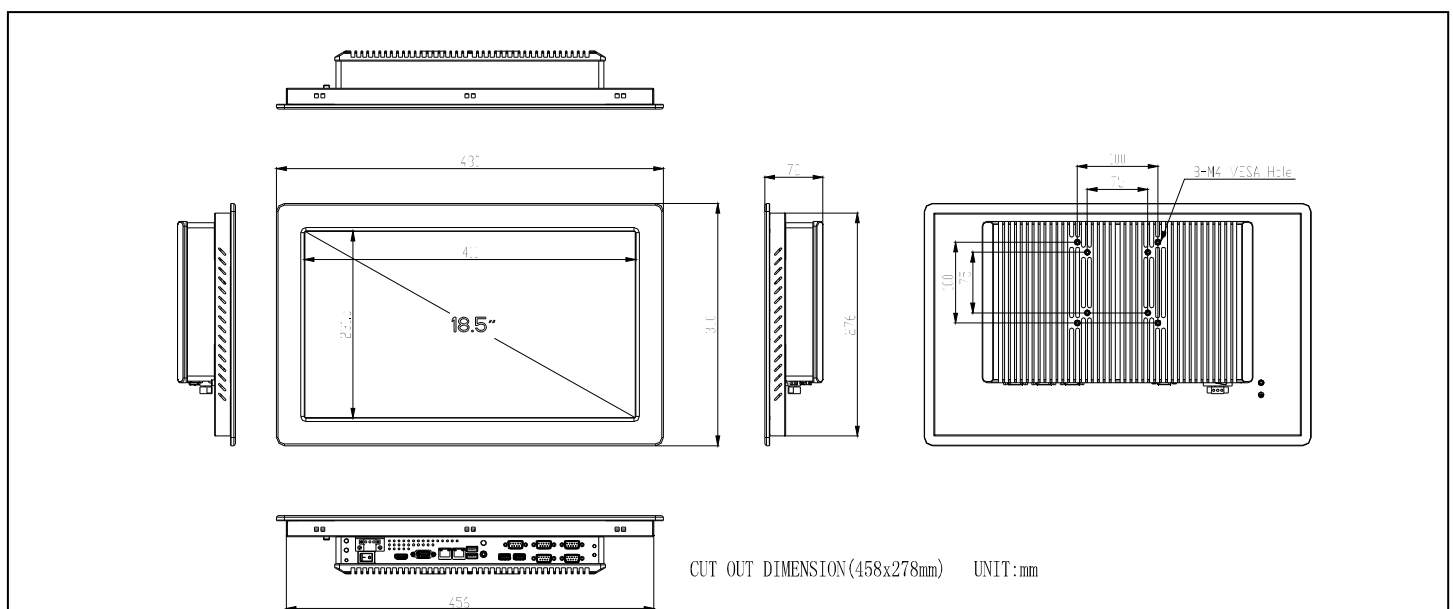

All specifications are subject to change without prior notice